



SATURN MAGNETIC

Operating and mounting manual gas- solenoid valve

Contents

- 1.0 Generality**
 - 1.1 Valve data
 - 1.2 Use provided for the valves
- 2.0 Danger warnings**
 - 2.1 Safety warning
 - 2.2 Skilful staff
 - 2.3 Trasfomation and production of non original spare parts
 - 2.4 Illicit methods of use
- 3.0 Treatment**
 - 3.1 Trasport
 - 3.2 Storing
 - 3.3 Treatment before assembling
- 4.0 Product description**
 - 4.1 Operation
 - 4.2 Technical data
 - 4.3 Distinguishing mark
- 5.0 Assembly**
 - 5.1 Warning regarding danger during assembly,use and service
 - 5.2 Assembly
 - 5.3 Before setting on-duty
 - 5.4 Servicing
- 6.0 Causes and remedies for operating anomalies**
 - 6.1 Mistakes research
 - 6.2 Plan of mistakes research
- 7.0 Disassembly of the valve**
 - 7.1 Replacement of worn pieces
- 8.0 Warranty**
- 9.0 Sectional Drawing, list of parts and detail**
- 10.0 Declaration of conformity Certificate**



SATURN MAGNETIC

1.0 Generality

The present directions for use contain all information for the correct assembly and operation of the solenoid valves:

Type SMR/7

Type DUPLOGAS

Contact the manufacturer if the present directions do not solve problems or difficulties.

The manufacturer reserves the right to carry out technical modifications or improvements at any moment.

In order to use the present installation and servicing directions the user is supposed to be skilled.

The directions for use must be always available where the system is used.

1.1 Valve data

Manufacturer:

SATURN MAGNETIC Snc

Via Lovati 29

I-20045 Besana B.za

Tel. +39 0362 942122

Fax: +39 0362 942132

E-Mail: info@saturnmagnetic.com

Homepage: www.saturnmagnetic.com

Applicant:

BETA VALVE SYSTEMS Ltd

Park House Business Centre

High Wycombe

Bucks HP 12 3DJ

Denomination:

NC valve with spring, direct control, electromagnetic operation.

SMR/7 Ø 2,0

DUPLOGAS Ø1,8-1,2

Type test acc.: CEI 107.31

Gas conformity: EN 161:2002 EN 61000-6-4:2001

Working pressure: 0-4 bar

Fluid temperature: -20°C + 60°C

Mounting position: With coil upright at 90° to vertical

Tension of connection: 12-24V DC

Insulation: IP65

Dimensions of thread connection: according to DIN ISO 228-1

Thread G (IN-OUT): 1/8"

More detailed information regarding electrical data and features are shown onto the label stuck on each coil.

1.2 Use provided for the valves

SA-MA gas solenoid valves are used as automatic shut off valves to protect, limit, close and unlock the gas supply.

These valves are suitable for gases belonging to gas families 1,2 and neutral.

In case of uses for working specifications different from the ones provided for, the user/customer has to check carefully if the construction of the valve, of the accessories and of the materials is suitable for the new type of use. The using field of the valve is within the competence of the person in charge of the system planning. The valve lasts for 15 years.



SATURN MAGNETIC

2.0 Danger warnings

The present instructions use the signs of DANGER, ATTENTION to point out basic passages for the correct use of SA-MA's solenoid valves.



DANGER! Means that in case of non-observance there could be a danger of life and/or a considerable material damage.



ATTENTION! Means that in case of non-observance there could be the risk of lesions and/or a damage to the material.

2.1 Safety warning

The non-observance of the safety warnings can cause the loss of every right of warranty.

It could cause:

- Danger for people, owing to electrical or mechanical effects.
- Anomalies to the system and to the solenoid valve
- Possible leakages of dangerous fluids.

2.2 Skilful staff

It refers to persons usually concerned with the installation, the assembly, the operation and the servicing of the product and endowed with the suitable skills for these activities and functions:

- Training and obligation to respect all all directions and regional and internal requirements due to the use.
- Training according to safety standards with regard to servicing and appropriate utilization for safety and accident-prevention protection.
- Instruction for first aid.

2.3 Transformation and production of non-original spare-parts.

Transformations or modifications of the valve are not allowed without previous agreements with the manufacturer.

The use of other parts or unlawful constructive modifications on the valve on behalf of a third part can lead to the annulment of the manufacturer's liability for the consequences that could result from these actions.

2.4 Illicit methods of use

For general security the limits indicated on the data label must never be exceeded.

- The fluid temperature must not exceed the temperature of the corresponding class.
- The pressure and the working cycle (ED) must never exceed the data shown onto the label.
- The valve must be connected to an earth system (if applicable).

It is possible to carry out this operation simply through the screws of the pipes by means of toothed washers bite.



SATURN MAGNETIC

3.0 Treatment

3.1 Transport

Safety caps must be mounted on both connections of the valve for the transport, the storing and the setting off-duty. The transported material must be handled with care. During the transport the valve must be protected from crashes, strokes and vibrations.

During the transport the temperature must be between -10°C and +50°C

Soon afterwards the receipt of the goods there must be a checking of the completeness of the supply and of possible transport damages.

3.2 Storing

If it is not immediately installed on delivery, the valve must be correctly stored.

-storehouse temperature from -10°C to +50°C, dry and clean.

-In damp environments it is necessary to warm up in order to avoid the forming of condensation.

3.3 Treatment before assembling

- Any mounted safety cap must be removed before assembling.

- It is necessary to protect from atmospheric agents, i.e. Dampness

- The correct use protects from damages.

4.0 Product description

SA-MA solenoid valves are normally closed valves, automatic shut off, direct control and electromagnetic operation, according to regulations. The valve construction is shown onto the sectional drawing of the chapter 9.0

4.1 Operation

Setting up the electromagnetic operation, the plunger is attracted towards the upper part. The spring of compression is pre-loaded and the plunger unlocks the valve's seat. The valve is open. The valve closes through disconnection, breakdown or interruption of the supply to the electromagnetic operation.

The valve is closed at 15% of the nominal tension.

4.2 Technical data

Opening times: 0,15 - 0,20s

Closing times: < 0.3s

Connection G :1/8

Torque N/m: 10-15 N/m

4.3 Distinguishing mark

Onto the label applied on the electromagnetic operation are reported the following data:

-Manufacturer

-Type of valve, nominal orifice, information regarding pressure and temperature

-Year of production / consignment

-Class and valve group according to DIN EN 161

-CE mark of the corporation indicated according to the regulation 97/23/CE

-Fluid group

-Electrical power

-Tension -5% +10%

-Frequency if applicable

-Insulation

-Seal



SATURN MAGNETIC

5.0 Assembly

5.1 Warnings regarding dangers during assembly, use and service



Danger! The safe operation of the valve is warranted only if the installation, the setting on-duty and the servicing of the valve are correctly carried out by skilful staff. Besides, it is requested the appropriate use of tools and protection equipments.

5.2 Assembly

In addition to the regulations generally valid concerning the assembly, the following points must be respected as well:

- Remove the safety caps from the connections.
- The internal parts of the valve and of the pipe must be without foreign bodies
- Notice the assembly position with regard to the flow (look at the marks onto the valve)
- Install the solenoid valve in a position accessible for any servicing.
- Assure an assembly without tensions.
- Protect the valves from obstruction, in particular in case of building works.

5.3 Before setting on-duty

- Before setting on-duty it is important to check and compare all instructions regarding material, pressure, temperature and flow direction with scheme of the pipes system.
- Depending on the field of use, local rules must be respected, i.e. security directions.
- Any residual product into the pipes and in the valve (dirtiness, slags of welding, etc.) inevitably causes the failure of closing.
- Carry out the seal test on the assembled valve.

5.4 Servicing

The operation and the internal seal of the valves must be checked at regular time's intervals. The user must fix the intervals of regular tests according to the working conditions. SA-MA advises to carry out a visual checking once a year.

6.0 Causes and remedies for operating anomalies

6.1 Mistakes research



Attention! While looking for a mistake it is important to follow scrupulously the security regulations. In case of operating anomalies it is necessary to verify if the assembly work has been carried out and achieved according to the present directions for use.

Moreover, it must be checked if the conditions of work correspond to the technical data shown onto the technical leaflet and label.

6.2 Plan of mistakes research

Anomalies ,Cause, potential Remedies

Inserting the electromagnetic operation the valve does not open

- check the tension
- working pressure too high. Compare the working pressure to the data shown onto the label

Lack of flow

- the safety caps have not been removed

Valve seat not hermetic, absence of internal seal.

- valve seal or seat damaged by foreign bodies



SATURN MAGNETIC

7.0 Disassembly of the valve



Danger!

Disconnect pressure into the pipes of supply

Disconnect the tension to the electromagnet

System evacuated

Ventilate the pipes system in case of liquids corrosive, inflammable, aggressive and toxic.

The assembly work must be carried out only by skilful staff.

7.1 Replacement of worn pieces



Attention!

OWING TO THE SMALL SIZES OF THE PARTICULARS AND TO THEIR FRAGILITY, IN CASE OF STROKES OR MISTAKES IT IS NECESSARY THAT THE INTERVENTION IS CARRIED OUT BY THE MANUFACTURER HIMSELF OR BY THE DEALER. SA-MA BELIEVES TO BE ABLE TO ESTABLISH ANY IMPROPER USE OR THE CORRECT REMEDY BY CHECKING THE CONDITION OF THE SOLENOID VALVES.

IN THE EVENT THE INTERVENT MUST BE CARRIED OUT IN THE USER'S PREMISES, CONTACT THE MANUFACTURER OR THE DEALER BEFOREHAND.

8.0 Warranty

The warranty lasts for 1 year but the user loses the right as soon as he carries out without notice any servicing, improper use or non-observance of the present directions of service and assembly.

Any justified complaint is dispatched after a checking on behalf of our Company or of specialized Companies appointed by us.

Servicing works and particulars to be replaced are included in the warranty; the shift of the assigned staff is not included.

Any transport damages must be declare immediately to the carrier.



SATURN MAGNETIC

9.0 Sectional Drawing and list of parts

SMR7 Solenoid valve

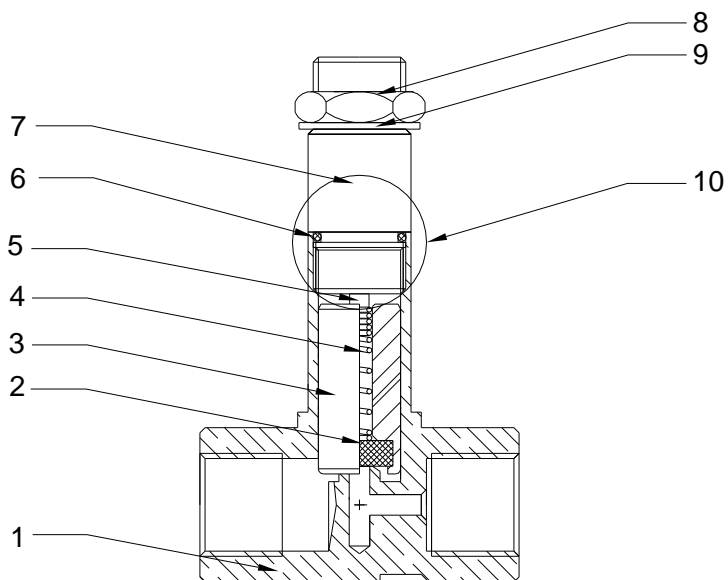

MECHANICAL PARTS			
N°	Description	Material	Specific
1	Body	OT 58	UNI5705/65 Cu58Zn40Pb2
2	Seal	Viton	Viton 70-75Sh
3	Plunger	AISI 430/F	UNI X10CrS17
4	Spring	AISI 302	UNI X10CrNi1809
5	Pivot	OT 58	UNI5705/65 Cu58Zn40Pb2
6	O-RING 105	Silicone	Silicone 75 Sh
7	Tube top	AISI 430/F	UNI X10CrS17
8	Nut	Fe	FeP04 Zn12IV(White)
9	Washer	Fe	FeP04 Zn12IV(White)
10	Threadlocker	Anaerobic Adesive	LOCTITE 638 (Gas Approved)

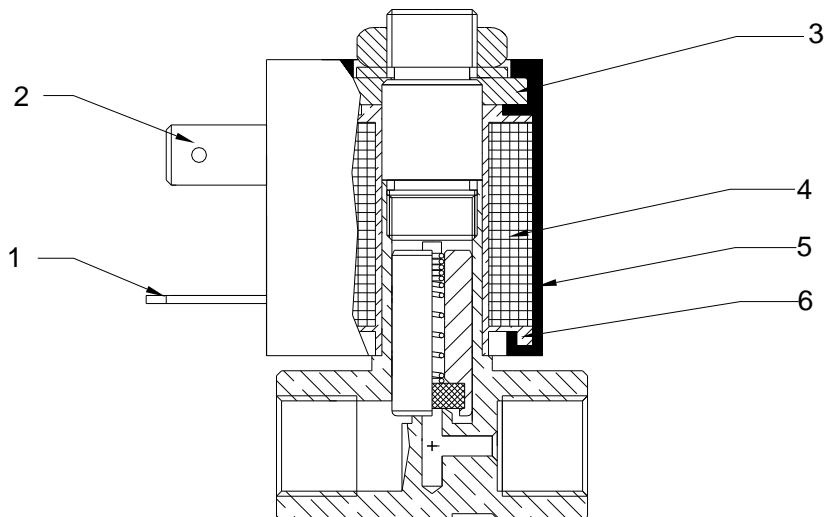

ELECTRICAL PARTS			
N°	Description	Material	Specific
1	Phase faston	OT63	UNI 4892 Cu63Zn47Pb0
2	Earth faston	Fe	FeP04 Zn12II(White)
3	Moulding	Fe	FeP04 Zn12II(White)
4	Winding	Copper Wire	HS 180°
5	Encapsulation	IXEF	PA 6+ 60%fiberglass
6	Reel	IXEF	PA 6+ 60%fiberglass



SATURN MAGNETIC

DUPLOGAS Solenoid valve

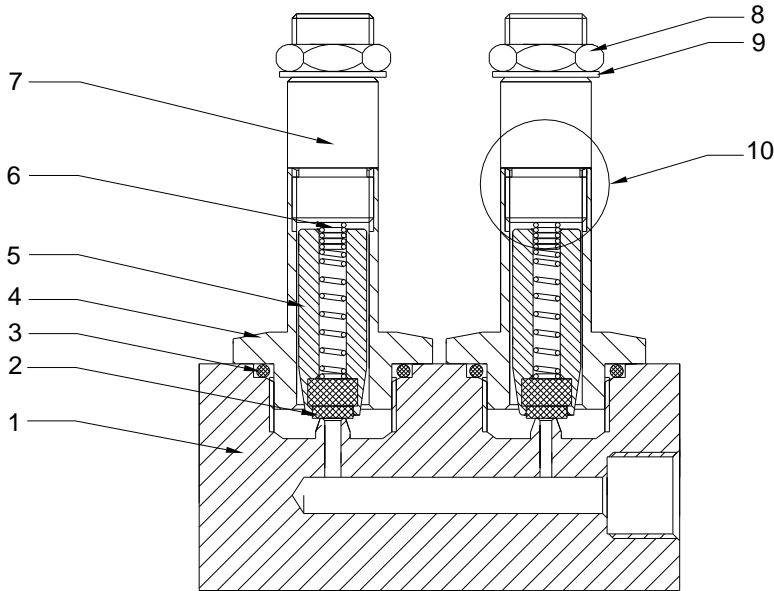

MECHANICAL PARTS			
N°	Description	Material	Specific
1	Body	Al.11S	UNI9002/5 PAL Cu5,5 Pb Bi
2	Seal	Viton	Viton 70-75Sh
3	O-RING 2056	Nbr	Nbr 75 Sh
4	Tube Guide	OT58	UNI5705/65 Cu58Zn40Pb2
5	Plunger	AISI 430/F	UNI X10CrS17
6	Spring	AISI 302	UNI X10CrNi1809
7	Tube top	AISI 430/F	UNI X10CrS17
8	Nut	Fe	FeP04 Zn12IV(White)
9	Washer	Fe	FeP04 Zn12IV(White)
10	Threadlocker	Anaerobic Adesive	LOCTITE 638 (Gas Approved)

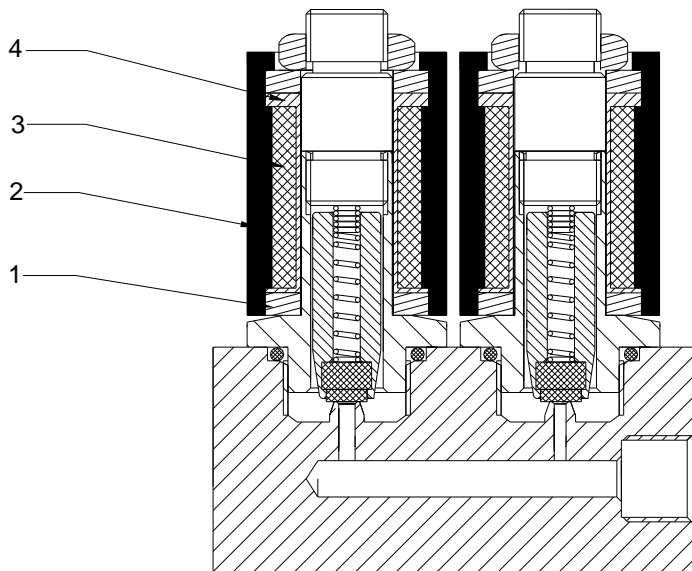

ELECTRICAL PARTS			
N°	Description	Material	Specific
1	Moulding	Fe	FeP04 Zn12II(White)
2	Encapsulation	IXEF	PA 6+ 60%fiberglass
3	Winding	Copper Wire	HS 180°
4	Reel	IXEF	PA 6+ 60%fiberglass



Solenoid valve SMR7

2/2 N.C. Direct action



SATURN MAGNETIC Snc

DESCRIPTION:

Direct action solenoid valve with melted guide tube. Minimum action pressure not requested. Seal and reliability are guaranteed by locking with threadlocker and OR between tube top and tube guide.

CLASS:	A
GROUP:	2
USE:	Gas
CONNECTION:	1/8"G.
COIL:	Sm7 Ø10 180°C classe H
SEAL:	

VITON			
155°C			

DETAILS:

CODE	DN G.	Ø Int*	kV M3/h	Δ P bar			T.a.	Power		Weight/gr
				min	max			VA	W	
					ac	dc				
5300*	1/8"	2,0	0,12	00	-	4	80°	-	4	120

Note:- Performances can decrease in DC with room temperature over 40°

RESPONSE TIME:

Ø 2,0 mm DIRECT ACTION 10-15 milliseconds

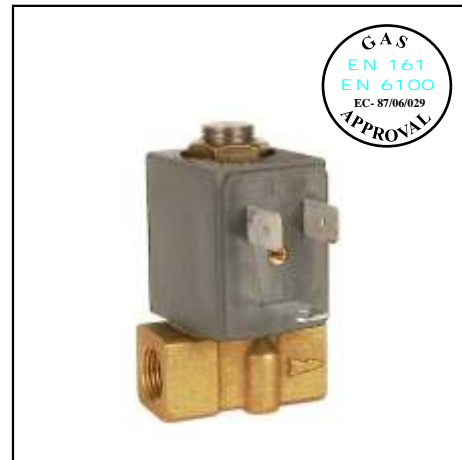
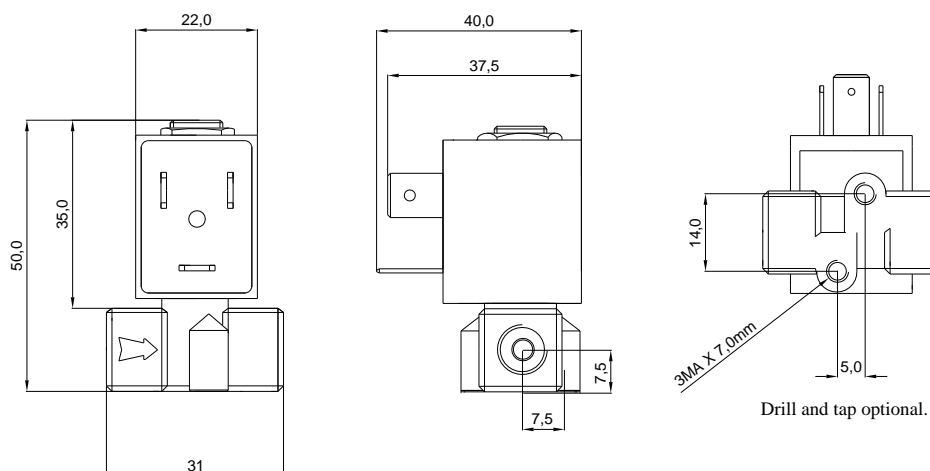
MEASURES:**COMPONENT PARTS-DETAILS:**

Body:	Moulded brass
Orifice:	Brass
Tube guide:	Moulded brass
Plunger:	Stainless steel (series 400)
Spring:	Stainless steel (series 300)
Insulation:	IP 65 with connector
Connection:	DIN 43650/B
Coil:	SM7 (encapsulation PA66-IXEF) 12 V DC Cod. 01800 24 V DC Cod. 01808

Code:

5300*180001: SMR7 Ø2,0 12V DC
5300*180801: SMR7 Ø2,0 24V DC

FITTINGS:

Connector:	Cod.02930
Hose holder:	Cod. 03350 (1/8"G. 6x3)



Solenoid valve DUPLOGAS

2/2 N.C. Direct action



SATURN MAGNETIC Snc

DESCRIPTION:

Direct action solenoid valve. Minimum action pressure not requested. Seal and reliability are guaranteed by locking with threadlocker between tube top and guide tube and with OR between body and tube guide. This solenoid valve allows the opening of only one part of the manifold or both at the same time to obtain a greater capacity.

CLASS:	A
GROUP:	2
USE:	Gas
CONNECTION:	1/8" G.
COIL:	Sm7 Ø10 180°C classe H
SEAL:	

VITON			
155°C			

DETAILS:

CODE	DN G.	Ø Int	kV M3/h	Δ P bar			T.a.	Power		Weight/gr
				min	max			VA	W	
					ac	dc				
5825*	1/8"	1,2*	0.04	00	-	4	80°	-	4	250
		1,8**	0.10	00	-	4	80°	-	4	

Note: -Standard Duplogas presents Ø1,2* beside the OUT; Ø1,8** beside the IN
- Performances can decrease in DC with room temperature over 40°

RESPONSE TIME:

Ø 2,0 mm DIRECT ACTION 10-15 milliseconds

MEASURES:

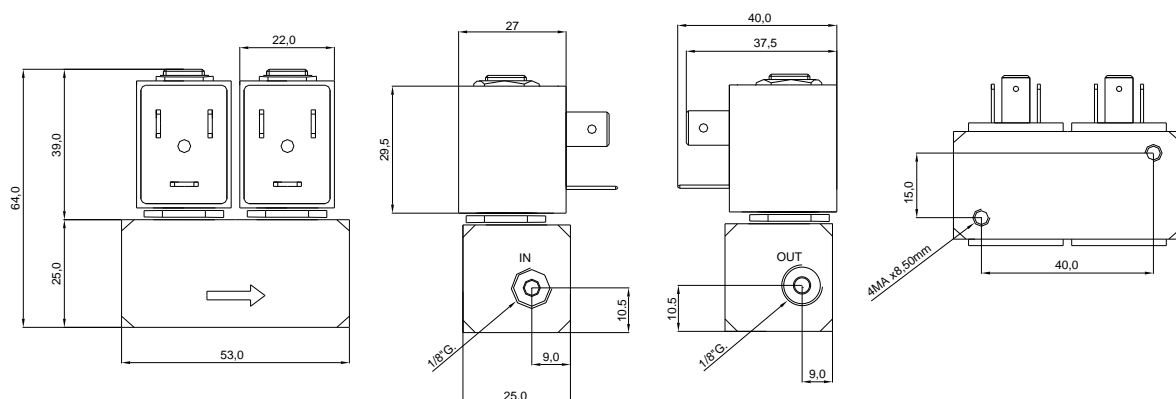

COMPONENT PARTS- DETAILS:

Body:	AL11S
Orifice:	AL 11S
Tube guide:	Brass
Plunger:	Stainless steel (series 400)
Spring:	Stainless steel (series 300)
Insulation:	IP 65 with connector
Connection:	DIN 43650/B
Coil:	Sm7 (encapsulation PA66-IXEF) 12 VDC Cod. 01800 24 V DC Cod. 01808

Code:

5825*180000: DUPLOGAS Ø1,8-1,2 12V DC
5825*180800: DUPLOGAS Ø1,8-1,2 24V DC

FITTINGS:

Connector:	Cod.02930
Hose holder:	Cod. 03350 (1/8" G. 6x3)



SATURN MAGNETIC

ADVANTICA

EC Type Examination Certificate

Issued by Advantica Certification Services

Certificate No.	EC-87/06/029/M1 (Page 1 of 2)	
Notified Body No.	0087	
Project No.	2/34112	
Date	19 January 2007	
Original/Supplementary	Supplementary	
	<u>Applicant</u> Beta Valve Systems Ltd. Park House Business Centre Desborough Park Road High Wycombe Bucks HP12 3DJ	<u>Manufacturer</u> Saturn Magnetic snc Via Lovati 29 Frazione Calo 20045 Besana Brianza Milano, Italy
Normative Reference	BS EN 161:2002	
EC Product Identification No.	C87BR29	
Model Designations	** See Appendix	

Declaration

Type samples representative of the products detailed have been tested and examined and found to comply with the Essential Requirements detailed in Annex I of the European Gas Appliance Directive (90/396/EEC).

Signed on behalf of the Advantica Notified Body (No. 0087)



Graham McKay, Manager, Certification Services
Advantica Limited, Ashby Road, Loughborough, Leicestershire LE11 3GR

Product Evaluation You Can Rely On

© 2004-2007 Advantica, Inc. 2004-2007 and Advantica Ltd. (formerly ISA). All rights reserved by the respective parties.



SATURN MAGNETIC



Appendix to Certificate EC-87/06/029/M1

Page 2 of 2

Product Type	Model Designation	Gas Category & Pressure	Destination Countries
Shut-off Valve	5300*180001 EV. SMR7 12V 5300*180801 EV. SMR7 24V 5825*180001 EV Duplogas 12V 5825*180801 EV Duplogas 24V	2 nd & 3 rd Family	All EU Countries

Note: This Supplementary Certificate has been issued due to the following modifications:

- (1) Up-rating of the maximum operating pressure from 2.0 bar to 4.0 bar;
- (2) Modified profile to outlet port;
- (3) Revised mounting attitude from coil upright to coil upright or 90° to vertical.

Application Warning: These devices may not be suitable for all applications and it is the responsibility of appliance designers to select the control devices that are appropriate for their specific product design.

Graham McKay, Manager, Certification Services
Advantica Limited, Ashby Road, Loughborough, Leicestershire LE11 3GR

Product Evaluation You Can Rely On



SATURN MAGNETIC



Advantica Limited
Certification Services
Ashby Road
Loughborough
Leicestershire
LE11 3GR

Telephone +44 (0) 1509 282086
Facsimile +44 (0) 1509 283113
e-mail: cert.serv@advanticagroup.com

**NOTIFICATION OF THE ISSUE OF AN EC TYPE EXAMINATION CERTIFICATE
UNDER THE EUROPEAN GAS APPLIANCE DIRECTIVE (90/396/EEC)**

SUPPLEMENTARY INFORMATION ON TECHNICAL DATA ("FORM B")

Certificate No. EC-87/06/029/M1

Notified Body No. 0087

Project No. 2/34112

Date 19 January 2007

Original/Supplementary Supplementary

Applicant

Beta Valve Systems Ltd.
Park House Business Centre
Desborough Park Road
High Wycombe
Bucks HP12 3DJ

Manufacturer

Saturn Magnetic snc
Via Lovati 29
Frazione Calo 20045
Besana Brianza
Milano, Italy

Normative Reference BS EN 161:2002

EC Product Identification No. C87BR29

Product Type	Model Designation	Gas Category & Pressure	Destination Countries
Shut-off Valve	5300*180001 EV. SMR7 12V 5300*180801 EV. SMR7 24V 5825*180001 EV Duplogas 12V 5825*180801 EV Duplogas 24V	2 nd & 3 rd Family	All EU Countries

Note: This Supplementary Certificate has been issued due to the following modifications:

- (1) Up-rating of the maximum operating pressure from 2.0 bar to 4.0 bar;
- (2) Modified profile to outlet port;
- (3) Revised mounting attitude from coil upright to coil upright or 90° to vertical.

Application Warning: These devices may not be suitable for all applications and it is the responsibility of appliance designers to select the control devices that are appropriate for their specific product design.



SATURN MAGNETIC

Name of Client: Beta Valve Systems
Product: SMR7 & Duplogas Valves
Certificate Number: EC-87/06/029/M1



Appendix to EC-87/06/029/M1

Description of Products Evaluated

The items tested are brass or aluminium bodied electrically actuated valves with stainless steel armature tube and spring. Solenoid coils are either 12 volt or 24 volt. Seals for gas use are NBR.

The SMR7 is a single solenoid variant and the Duplogas is a twin solenoid version.

Declared Data

Class of valve	Class A
Group 1 or Group 2	Group 2
Permissible mounting attitude(s)	With coil upright or at 90° to vertical
Operating temperature range	0°C to 80°C
Rated flow-rate	Duplogas 0.085m ³ /h (SG: 1.0) @ 25mbar pd SMR7 0.095m ³ /h (SG: 1.0) @ 25mbar pd
Maximum working pressure	4.0 bar
Inlet connection type & size	G 1/8"
Outlet connection type & size	G 1/8"
Rated voltage of valve	12 V dc, 24 V dc (4 W)
Opening time	< 1.0 sec
Closing time	< 1.0 sec